



DeLaval vacuum pump LVP

Your heavy-duty vacuum supplier



DeLaval vacuum pump LVP for long operating times

DeLaval vacuum pump LVP is designed for you, the dairy farmer who demands the utmost in performance.

With a capacity range of 2,500 to 5,660 litres per minute (at 50 kPa) and a minimum maintenance requirement, this is truly heavy-duty vacuum supply. DeLaval vacuum pump LVP gives you reliability without sacrificing performance, especially when you have long operating times.

Providing optimum vacuum output per hour of operation, the three models – LVP 3000, LVP 4500 and LVP 6000 – represent the best in vacuum technology.

DeLaval vacuum pump for peace of mind

With DeLaval vacuum pump LVP, reliability comes built in. It has to, because without vacuum your milking system comes to a standstill.

Utilising efficient and well-proven vacuum and motor technology, these suppliers draw on the decades of vacuum experience we have here at DeLaval. Due to the special design of the pump head, the maintenance requirement has been reduced to an absolute minimum, saving your operating costs.

Each pump head is also equipped with a cleaning device. Any residue can be quickly and simply removed, removing any need for dismantling and avoiding down time



Hour meter



DeLaval vacuum pump for the environment

The pump is designed to be both heavy duty and environmentally friendly.

Lobe pump technology ensures that the environment is left undisturbed – no oil is needed for sealing or lubrication. DeLaval vacuum pump LVP draws in the same air as it pumps out; air that is kept clean and free from oil.

With built-in noise reduction the LVP range is also quiet, leaving you to milk undisturbed.

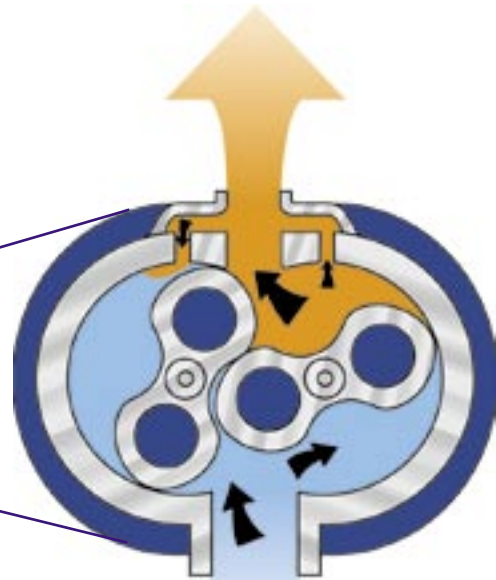

The DeLaval vacuum pump LVP, with its unique discharge plenum chamber, results in a much smoother vacuum level and a quiet run.



Filter



Cleaning device

Key features

The pump head includes two figure-eight lobes, rotating in opposite directions. With every rotation, a constant volume of air is transferred.

Unique to DeLaval vacuum pump LVP is the discharge plenum chamber, situated at the pump head outlet. This special feature gives you a much smoother and quieter run.

Timing is controlled by the discharge gearbox. Exclusive on today's market, this gearbox has been designed entirely for vacuum application and ensures that exact clearance is maintained.

Since the closely-aligned lobes never touch, no lubricant is required within the pump unit itself.

The highly-efficient distribution tank filter protects your investment

even further by filtering out particles larger than 10 microns, which can be harmful for the pump.

All these aspects mean operating efficiency under tough conditions, saving you from downtime and maintenance costs. And because DeLaval vacuum pump LVP comes pre-assembled, it can be installed between milkings and is ready to go to work as soon as you are.

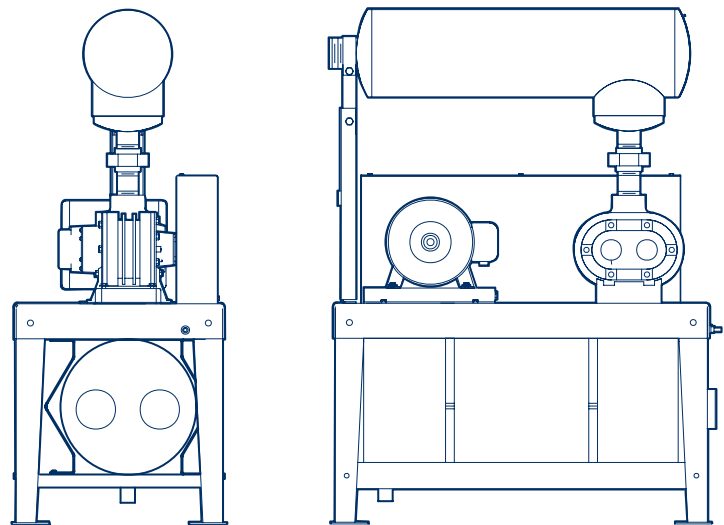

Which model for my farm?

To match the right model – LVP 3000, LVP 4500 or LVP 6000 – to your dairy farm’s vacuum requirements:

Supplier capacity* l/min (CFM) @						
Models	Power	42kPa/12.4"	44 kPa/13"	46 kPa/13.6"	48 kPa/14.2"	50 kPa/15"
LVP 3000	50 Hz	3680 (130)	3500 (124)	3325 (118)	3165 (112)	3000 (106)
	60 Hz	3200 (113)	3035 (107)	2890 (102)	2745 (97)	2515 (89)
LVP 4500	50 Hz	5310 (188)	5070 (180)	4840 (171)	4615 (163)	4325 (153)
	60 Hz	5340 (189)	5120 (181)	4860 (172)	4640 (164)	4350 (154)
LVP 6000	50 Hz	6850 (242)	6550 (231)	6250 (221)	5930 (210)	5600 (197)
	60 Hz	6960 (246)	6660 (235)	6340 (224)	6050 (214)	5660 (200)

*At sea level